

# 外觀圖

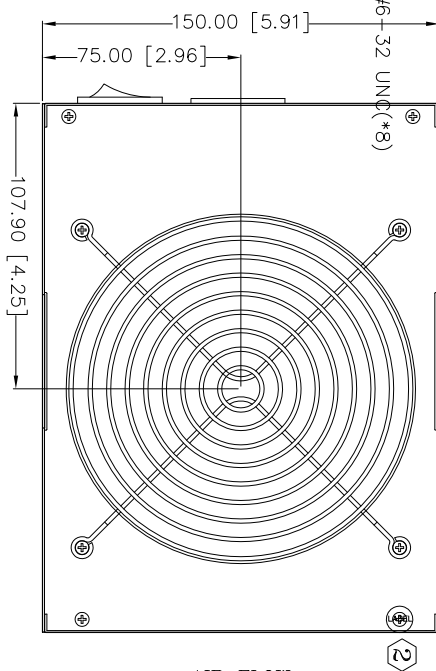

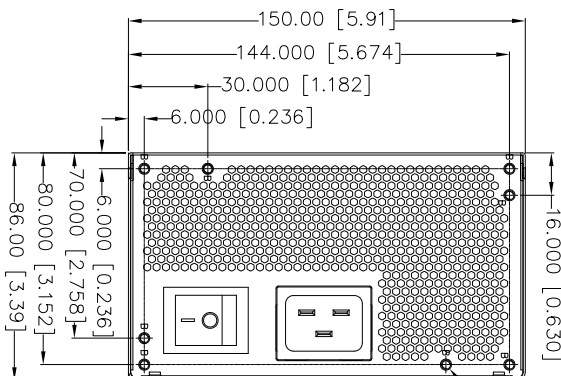

AIR FLOW

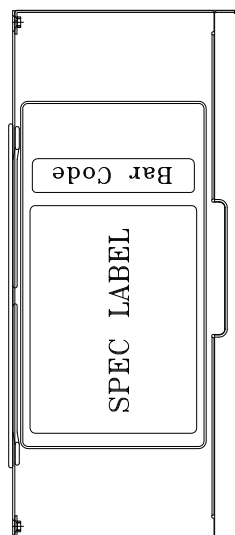
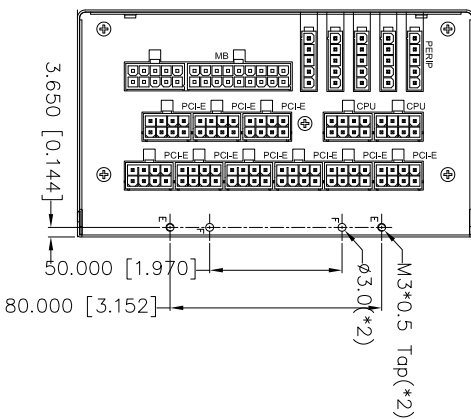

NOTE:

1. ALL THE LENGTH OF OUTPUT WIRES EXCLUDE HOUSING.
2. 公差: .XX=±0.5 [0.02]、.XXX=±0.25 [0.01]

P/N.:PPA20A0400

UNIT:mm

MODEL NO. : FSP2000-52ACPB1,IEC62368,(STD0001)	TITLE: ASSY	SHEET: 1 OF 3 REV:01
R&D(2)	PE	DRAWN
INTERIOR COUNTERSIGN:		DATE
		DEC.25.2020

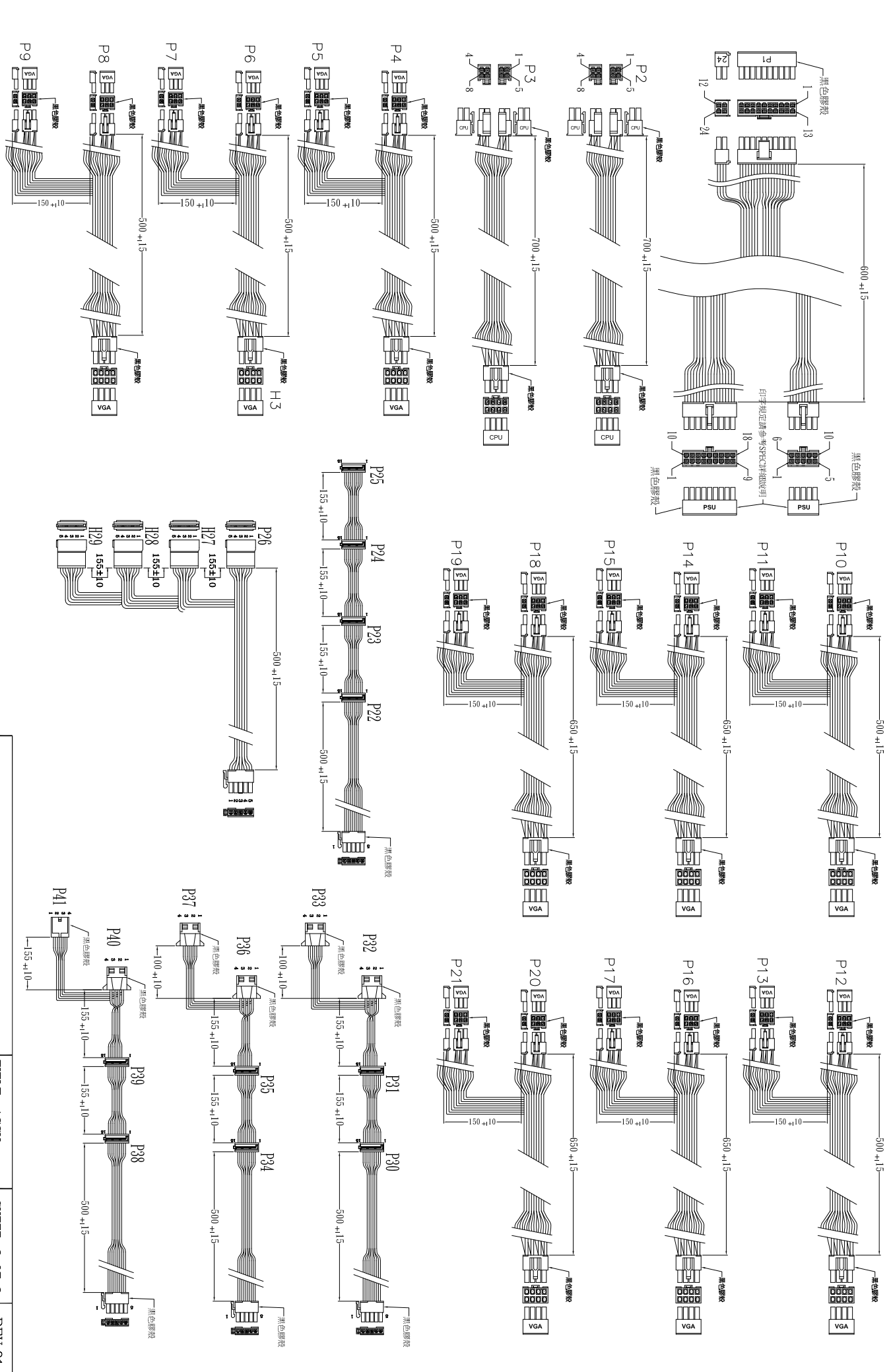

UNIT:mm

TITLE: ASSY

SHEET: 2 OF 3

REV:01

REF. ID.	PIN NO.	SIGNAL	WIRE COLOR	GAUGE	CONNECTOR TYPE	CABLE LENGTH
P1 24	1	+3.3VDC	BALCK	16	WST P20- 142002K11D-B +P4- 142002K11D-B or EQUIV.	600±15mm
	2	+3.3VDC	BALCK	16		
	3	+3.3VSense	BALCK	22		
	4	COM	BALCK	16		
	5	+5V	BALCK	16		
	6	COM	BALCK	16		
	7	+5V	BALCK	16		
	8	+5V Sense	BALCK	22		
	9	COM	BALCK	16		
	10	PW-OK	BALCK	22		
	11	+5Vsb	BALCK	16		
	12	+12V	BALCK	16		
	13	+3.3VDC	BALCK	16		
	14	+3.3VDC	BALCK	16		
	15	-12VDC	BALCK	16		
	16	COM	BALCK	16		
	17	PS-ON	BALCK	22		
	18	COM	BALCK	16		
	19	COM	BALCK	16		
	20	COM	BALCK	16		
	21	+5V	BALCK	16		
	22	+5V	BALCK	16		
	23	+5V	BALCK	16		
	24	+5V	BALCK	16		
P2	1	COM	BALCK	16	WST P4- 142002K3B-B4 +P4- 142002K4B-B4 or EQUIV.	700±15mm
	2	COM	BALCK	16		
	3	COM	BALCK	16		
	4	COM	BALCK	16		
	5	+12V	BALCK	16		
	6	+12V	BALCK	16		
	7	+12V	BALCK	16		
	8	+12V	BALCK	16		
P4	1	+12V	BALCK	16	WST P6-142002 K21-B6 +P2-142002 K13B-B or EQUIV.	500±15mm
	2	+12V	BALCK	16		
	3	+12V	BALCK	16		
	4	+12V	BALCK	16		
P8	5	COM	BALCK	16	WST P6-142002 K21-B6 +P2-142002 K13B-B or EQUIV.	500±15mm
	6	COM	BALCK	16		
P10	7	COM	BALCK	16	WST P6-142002 K21-B6 +P2-142002 K13B-B or EQUIV.	500±15mm
	8	COM	BALCK	16		
P12	9	COM	BALCK	16	WST P6-142002 K21-B6 +P2-142002 K13B-B or EQUIV.	500±15mm
	10	COM	BALCK	16		

P14	1	+12V	BALCK	18	WST P6-142002 K21-B6 +P2-142002 K13B-B or EQUIV.	650±15mm
	2	+12V	BALCK	18		
	3	+12V	BALCK	18		
	4	COM	BALCK	18		
	5	COM	BALCK	18		
	6	COM	BALCK	18		
	7	COM	BALCK	18		
	8	COM	BALCK	18		
	9	COM	BALCK	18		
	10	COM	BALCK	18		
	11	COM	BALCK	18		
	12	COM	BALCK	18		
	13	COM	BALCK	18		
	14	COM	BALCK	18		
	15	COM	BALCK	18		
	16	COM	BALCK	18		
	17	COM	BALCK	18		
	18	COM	BALCK	18		
	19	COM	BALCK	18		
	20	COM	BALCK	18		
	21	COM	BALCK	18		
	22	COM	BALCK	18		
	23	COM	BALCK	18		
	24	COM	BALCK	18		
P22	1	+3.3VDC	BALCK	18	MOLEX SD-67926 -0011 or EQUIV.	500±15mm
	2	COM	BALCK	18		
	3	+5V	BALCK	18		
	4	COM	BALCK	18		
	5	+12V	BALCK	18		
	6	+3.3VDC	BALCK	18		
	7	COM	BALCK	18		
	8	COM	BALCK	18		
P23	1	+3.3VDC	BALCK	18	MOLEX SD-67926 -0011 or EQUIV.	155±10mm
	2	COM	BALCK	18		
	3	+5V	BALCK	18		
	4	COM	BALCK	18		
	5	+12V	BALCK	18		
P24	1	+3.3VDC	BALCK	18	MOLEX SD-67926 -0011 or EQUIV.	155±10mm
	2	COM	BALCK	18		
	3	+5V	BALCK	18		
	4	COM	BALCK	18		
	5	+12V	BALCK	18		
P25	1	+3.3VDC	BALCK	18	MOLEX SD-67926 -0011 or EQUIV.	155±10mm
	2	COM	BALCK	18		
	3	+5V	BALCK	18		
	4	COM	BALCK	18		
	5	+12V	BALCK	18		
P26	1	+3.3VDC	BALCK	18	MOLEX SD-67926 -0011 or EQUIV.	155±10mm
	2	COM	BALCK	18		
	3	+5V	BALCK	18		
	4	COM	BALCK	18		
	5	+12V	BALCK	18		
P27	1	+3.3VDC	BALCK	18	MOLEX SD-67926 -0011 or EQUIV.	155±10mm
	2	COM	BALCK	18		
	3	+5V	BALCK	18		
	4	COM	BALCK	18		
	5	+12V	BALCK	18		
P28	1	+3.3VDC	BALCK	18	MOLEX SD-67926 -0011 or EQUIV.	155±10mm
	2	COM	BALCK	18		
	3	+5V	BALCK	18		
	4	COM	BALCK	18		
	5	+12V	BALCK	18		
P29	1	+3.3VDC	BALCK	18	MOLEX SD-67926 -0011 or EQUIV.	155±10mm
	2	COM	BALCK	18		
	3	+5V	BALCK	18		
	4	COM	BALCK	18		
	5	+12V	BALCK	18		

P30	1	+3.3VDC	BALCK	18	MOLEX SD-67926 -0011 or EQUIV.	500±15mm
	2	COM	BALCK	18		
	3	+5V	BALCK	18		
	4	COM	BALCK	18		
P34	1	+12V	BALCK	18	MOLEX SD-67926 -0011 or EQUIV.	155±10mm
	2	COM	BALCK	18		
	3	+5V	BALCK	18		
	4	COM	BALCK	18		
	5	+12V	BALCK	18		
P38	1	+3.3VDC	BALCK	18	MOLEX SD-67926 -0011 or EQUIV.	155±10mm
	2	COM	BALCK	18		
	3	+5V	BALCK	18		
	4	COM	BALCK	18		
	5	+12V	BALCK	18		
P31	1	+3.3VDC	BALCK	18	MOLEX SD-67926 -0011 or EQUIV.	155±10mm
	2	COM	BALCK	18		
	3	+5V	BALCK	18		
	4	COM	BALCK	18		
	5	+12V	BALCK	18		
P35	1	+12V	BALCK	18	MOLEX SD-67926 -0011 or EQUIV.	155±10mm
	2	COM	BALCK	18		
	3	+5V	BALCK	18		
	4	COM	BALCK	18		
	5	+12V	BALCK	18		
P39	1	+12V	BALCK	18	MOLEX SD-67926 -0011 or EQUIV.	155±10mm
	2	COM	BALCK	18		
	3	+5V	BALCK	18		
	4	COM	BALCK	18		
	5	+12V	BALCK	18		
P32	1	+12V	BALCK	18	MOLEX SD-67926 -0011 or EQUIV.	155±10mm
	2	COM	BALCK	18		
	3	+5V	BALCK	18		
	4	COM	BALCK	18		
	5	+12V	BALCK	18		
P36	1	+12V	BALCK	18	MOLEX SD-67926 -0011 or EQUIV.	155±10mm
	2	COM	BALCK	18		
	3	+5V	BALCK	18		
	4	COM	BALCK	18		
	5	+12V	BALCK	18		
P33	1	+12V	BALCK	18	MOLEX SD-67926 -0011 or EQUIV.	155±10mm
	2	COM	BALCK	18		
	3	+5V	BALCK	18		
	4	COM	BALCK	18		
	5	+12V	BALCK	18		
P37	1	+12V	BALCK	18	MOLEX SD-67926 -0011 or EQUIV.	155±10mm
	2	COM	BALCK	18		
	3	+5V	BALCK	18		
	4	COM	BALCK	18		
	5	+12V	BALCK	18		
P40	1	+12V	BALCK	18	MOLEX SD-67926 -0011 or EQUIV.	155±10mm
	2	COM	BALCK	18		
	3	+5V	BALCK	18		
	4	COM	BALCK	18		
	5	+12V	BALCK	18		
P41	1	+12V	BALCK	18	MOLEX SD-67926 -0011 or EQUIV.	155±10mm
	2	COM	BALCK	18		
	3	+5V	BALCK	18		
	4	COM	BALCK	18		
	5	+12V	BALCK	18		

UNIT:mm

TITLE: ASSY

SHEET: 3 OF 3

REV:01