

ELECTRIC MASTER II Deluxe



Motorized screen for ceiling or wall mounting. Professional quality for highest demands. The Click-Mounting set allows for fast and easy installation on the wall or on the ceiling. An IR-receiver is integrated in the elegant, slim aluminium housing. A handheld remote control is included. An additional, wired IR-receiver is provided for inconcealed installation of the screen housing.

The solid housing, the warp resistant roller and the heavy bar insuring the perfect tension of the screen.

The very fast and quiet Somfy-Motor and adjustable limit switches make the ElectricMaster II Deluxe the ideal choice for most applications. The black rear surfaces and the black masking borders guarantee best contrast and full reflection of projection light. All screen surfaces are seamless.

Features

- Motorized screen for wall- or ceiling mounting
- IR-receiver included in housing; IR-remote control included
- Additional, wired IR-receiver included for installations, where the screen's housing is out of the line of sight of the IR-remote.
- Elegant square bar housing, white coloured; aluminium
- Easy and quick installation
- Adapters for easy Mounting
- Very quick and quiet Somfy-Motor
- Adjustable limit switches allow for the upper and lower end positions to be defined by presets
- Advanced control options with Control Panel on housing's left
 - Switcher for IR remote control / manual control
 - switch for „Up“, „Down“, „Stop“
 - RS-232 interface
 - USB control with adapter / IP (optional)
- The Matte White screen surface with black borders is seamless
- HDTV and 16:10 Formats come with additional black drop, which allows for the screen to be mounted in a standard eight foot ceiling to bring the screen to a comfortable viewing height.

Screen surface

MATTE WHITE

Specifications

Motorized projection screen, for wall-or ceiling mounting. Motor with integrated thermic overload protection and electric brake. Comes with connection cables and IR control. Housing: Aluminium base alloy, squared shape. Housing colour: White.

Size of the projection surface is adjustable to any height. Upper and lower end position can be defined by presets. Projection surface with black masking borders.

Screen surface MATTE WHITE:

Matte white surface, fiber glass surface base material, washable, aging resistant, heavy duty materials, flame retardant.

Gain factor 1,0 – Viewing angle $\pm 50^\circ$

Dimensions: _____ x _____ cm, H x W;

Motor: 220 Volt, 50 Hz, 0,4 A

Manufacturer: COMM-TEC

Type: ElectricMaster II Deluxe

ELECTRIC MASTER II Deluxe

Connections / Control

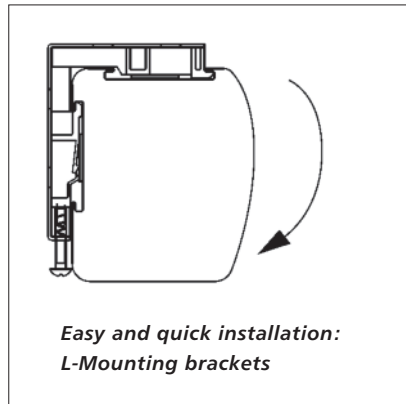

Specifications

	Format (cm) H x B	Cat.-Nr.	Housing length (cm)	Housing height (mm)	Housing width (mm)	Weight (kg)	Black masking border le/ri(cm)	Black masking border up/down (cm)
4:3 Video – plus black masking borders								
100"	152 x 203	43FADX-100-IR	234,4	126	119	16,2	5	8/8
120"	180 x 240	43FADX-120-IR	265,4	126	119	20,0	5	8/8
150"	229 x 305	43FADX-150-IR	336,4	126	119	29,4	5	8/8
16:9 HDTV – plus black masking borders + 40cm black drop								
92"	114 x 203	43FADX-092X-IR	234,4	126	119	16,0	5	40/8
106"	132 x 234	43FADX-106X-IR	265,4	126	119	20,0	5	40/8
120"	149 x 266	43FADX-120X-IR	297,0	126	119	21,8	5	40/8
150"	187 x 332	43FADX-150X-IR	363,4	126	119	34,1	5	40/8
16:10 – plus black masking borders + 30cm black drop								
124"	166 x 266	43FADX-124X-IR	298,5	128	121	20,5	5	30/8
140"	188 x 301	43FADX-140X-IR	332,9	128	121	30,5	5	30/8

Accessories (included in delivery)

- Wall-/ Ceiling mounting brackets
- Brackets for hanging mounting
- IR-Receiver built in
- IR-Remote control
- Power Cord with Plug
- Additional wired IR-receiver

Accessories (optional)

- In ceiling mount set for all dimensions available
- RS-232 plug / USB control via adapter / LAN
- Manual switch for Up-Stop-Down control of the screen